

ASSEMBLED MODEL NO.	PLUNGER PART NO.	CAM STYLE	ASSEMBLED ORIENTATION
LI-4040-10-S-0	81400213	STR	0
LI-4040-10-S-60			60
LI-4040-10-S-120			120
LI-4040-10-S-30			30
LI-4040-10-S-90			90
LI-4040-10-S-150	81400223	LH	150
LI-4040-10-L-0			0
LI-4040-10-L-60			60
LI-4040-10-L-120			120
LI-4040-10-L-30			30
LI-4040-10-L-90	81400253	RH	90
LI-4040-10-L-150			150
LI-4040-10-R-0			0
LI-4040-10-R-60			60
LI-4040-10-R-120			120
LI-4040-10-R-30	81400263	RH	30
LI-4040-10-R-90			90
LI-4040-10-R-150			150

NO	QTY	PART NO	DESCRIPTION	SEAL KIT	CLEVIS PIN KIT
1	3	23050036	RING, RTNG, EXT, 0.394		X
2	2	23340003	STOCK, CORD, .38 X .88, 50, NBR		X
3	3	23350086	SPRING, COMPRESSION	X	
4	3	23650010	BALL, TUNGSTEN-CARBIDE, 6mm	X	
5	2	39051079	O-RING, (6mm X 1)	X	
6	1	39051083	O-RING, (41mm X 2)	X	
7	2	39051087	O-RING, (4mm X 3)	X	
8	1	39053043	SEAL, WIPER, SNAP IN, WED, 22, 94A, AU	X	
9	1	39056003	SEAL, STEP, ROD, 22	X	
10	1	39056023	SEAL, CAP, PISTON, 40, 90A, AU GRPHT FLD	X	
11	2	43068004	PLUG, SOCH, G1/8		
12	1	81400153	CAP, LC/SC, 7MPa, 40B		
13	2	81400200	PLUG, MANIFOLD, 7MPa, M6		
14	3	81400203	PIN, STOP, BALL, METRIC, 6mm BALL	X	
15	1	81400273	PIN, ROCKER, SC, 7MPa, 40B		X
N/A	N/A	L6014400	KIT, SEAL, SC, 7MPa, 40B	NOTED	N/A
N/A	N/A	L6214400	KIT, CLEVIS PIN, SC, 7MPa, 40B	N/A	NOTED

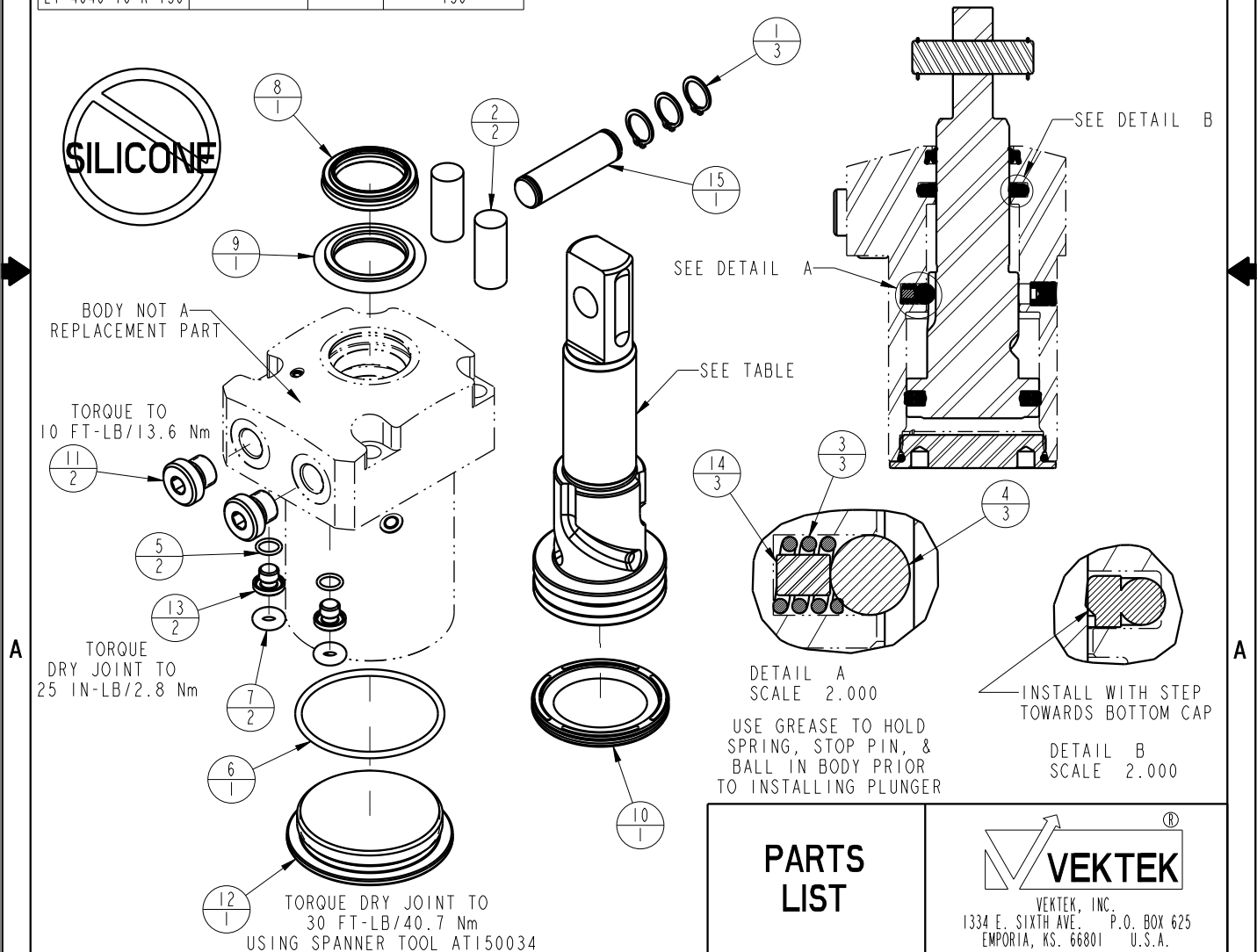

PARTS LIST		VEKTEK	
ASSEMBLIES AFFECTED SEE ASSEMBLY MODEL NO. TABLE ABOVE		VEKTEK, INC. 1334 E. SIXTH AVE. P.O. BOX 625 EMPORIA, KS. 66801 U.S.A.	
SIZE A	LPL1426	REV B	

B	3273	RELEASE	JDW	08/15/18
REV	IN ACCORDANCE WITH ECN	EFFECTIVE DATE	REVISED BY	DATE
DRW BY: MAJ	DRAWING STATUS: Released			
DATE: 4-16-15	PRODUCTION APPROVED FOR RELEASED STATUS ONLY			